

PERI UP Flex Shoring Tower MDS K

The efficient shoring tower with system-integrated safety for vertical assembly and dismantling

Product Brochure – Issue 03/2019

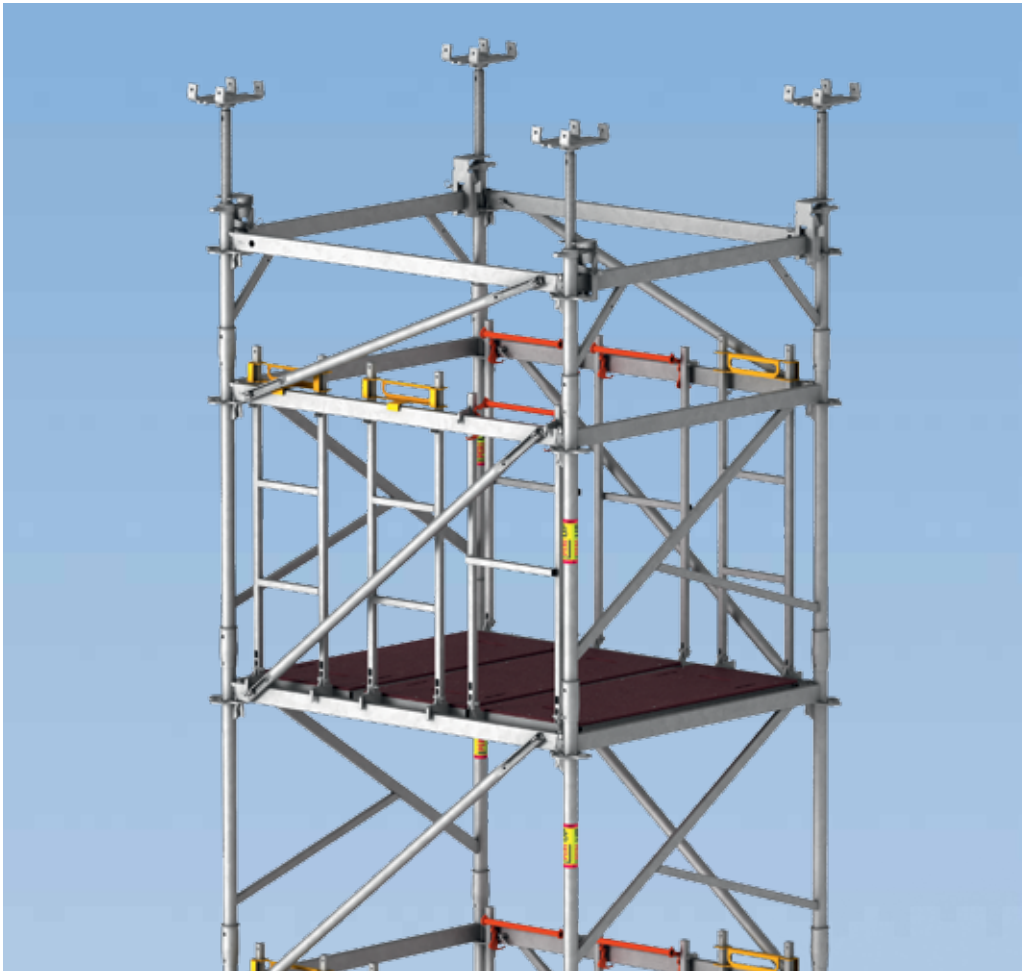

Content

System Advantages

- 5 The efficient shoring tower with system-integrated safety for vertical assembly and dismantling
- 6 Safe assembly without any additional components
- 8 Accelerated working operations
- 10 Effortless handling

System Overview

- 12 PERI UP Flex Shoring Tower MDS K at a glance

Standard Applications

- 14 Height adjustment and loading multiplication

System Supplements

- 16 Moving with the crane or Trolley with Winch
- 17 Storage and transportation

Issue 03/2019

Publisher

PERI GmbH
Formwork Scaffolding Engineering
Rudolf-Diesel-Strasse 19
89264 Weissenhorn
Germany
info@peri.com
www.peri.com

Components

- 18 Component overview of the
PERI UP Flex Shoring Tower
MDS K

Important Information

All current safety regulations and guidelines applicable in those countries where our products are used must be observed.

The images shown in this brochure feature construction sites in progress. For this reason, safety and anchor details in particular cannot always be considered conclusive or final. These are subject to the risk assessment carried out by the contractor.

In addition, computer graphics are used which are to be understood as system representations. To ensure a better understanding, these and the detailed illustrations shown have been partially reduced to show certain aspects. The safety in-

stallations which have possibly not been shown in these detailed descriptions must nevertheless still be available. The systems or items shown might not be available in every country.

Safety instructions and load specifications are to be strictly observed at all times. Separate structural calculations are required for any deviations from the standard design data.

The information contained herein is subject to technical changes in the interests of progress. Errors and typographical mistakes reserved.



PERI UP Flex Shoring Tower MDS K

The efficient shoring tower with system-integrated safety for vertical assembly and dismantling

The PERI UP Flex Shoring Tower MDS K is used in shoring constructions for transferring vertical and horizontal loads. The system allows system-integrated safe assembly without any accessories.

Ensuring the safety of workers on the construction site is an absolute priority. Therefore, PERI has been developing systems over many years that provide a fast and efficient application together with a very high level of safety.

With the MDS K Shoring Tower, all levels of the tower are assembled and dismantled using the protection of a guardrail in advance. In this way, users are guaranteed safe working conditions for all assembly situations.

The platforms are an integral part of the Shoring Tower MDS K. They lock automatically in position when inserted. This construction accelerates the handling and simultaneously provides a high level of safety.

The simple assembly sequence with a small number of system components ensures working operations are fast and cost-effective. The lightweight components and optimised working movements guarantee an ergonomic posture during the assembly and dismantling of the shoring tower.

As a free-standing shoring tower up to an assembly height of 6.39 m, the MDS K is designed to accommodate loads up to 48 kN. If the Shoring Tower MDS K is restrained at the top, towers up to 21.39 m high can be erected and accommodate loads up to 50 kN.

In order to ensure a long service life, all components of the shoring tower are galvanised.

Safe assembly without any additional components

due to the specific type of design with Platforms MDS and peripheral guardrails

Accelerated working operations

with only a minimum of system components and constantly repeated assembly steps

Effortless handling

due to the low weight and ergonomically advantageous working operations in the centre of the body

Safe assembly without any additional components

due to the specific type of design with the Platform MDS and peripheral guardrails

Assembly and dismantling of the Shoring Tower MDS K takes place with protection always provided by means of end-to-end guardrails. The user is always in a safe and secure position during all assembly situations.

The platforms in the Shoring Tower MDS K are integrated into a recurring and identical assembly sequence. The erection of the shoring tower and deck installation is carried out simultaneously and continuously, regardless of the height.

The Platforms MDS are mounted on the ledgers without any tools. There are no additional work steps and no temporary stages of construction that would need to be separately secured. This likewise applies to both the assembly and dismantling procedures.

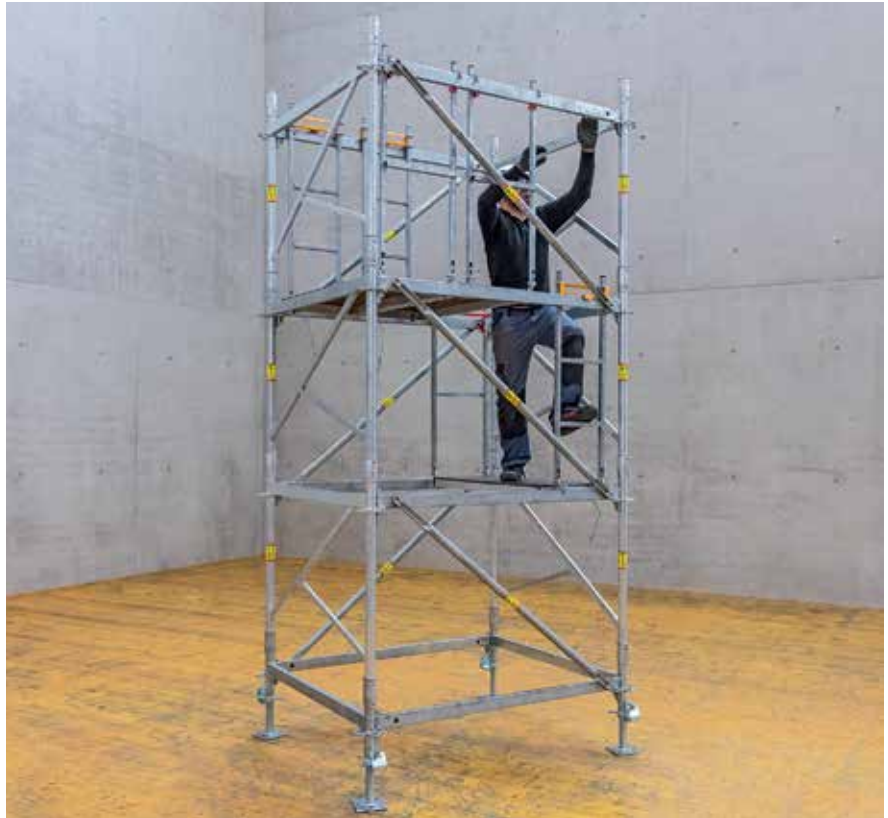

A high degree of safety is integrated in the system. The user "climbs up" using the platforms inside the tower during assembly of the shoring tower. Thereby, site personnel are always secured by means of a peripheral guardrail.

Moving the working levels

- Only 3 platforms in the shoring tower with dimensions of 1.25 m x 1.50 m.
- The side parts of the platforms have colour markings in order to accelerate working operations.
- Firstly, the side with the yellow-marked guardrails is always mounted in the next level; the red-marked side is subsequently installed.
- The user only accesses the next highest level before moving the last platform.

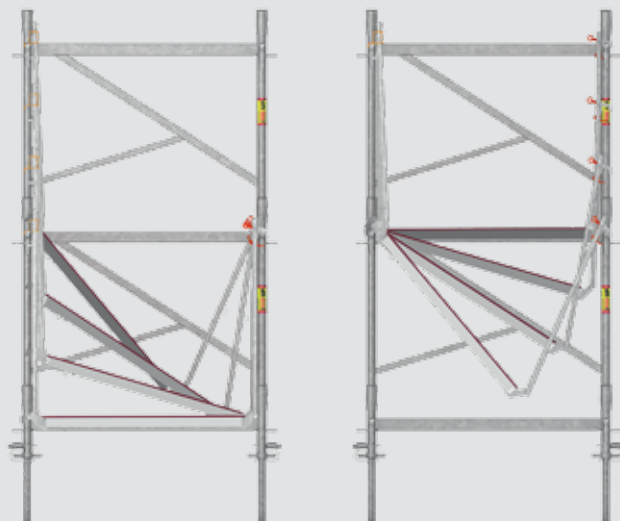

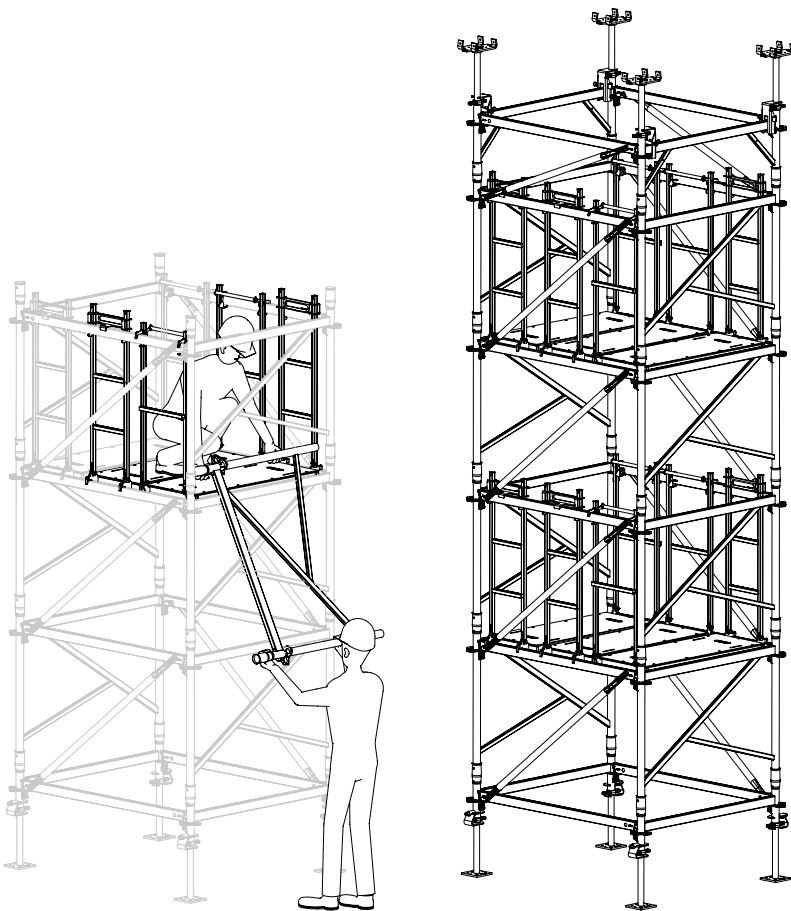

The working levels ensure easy access to the tower in accordance with all applicable regulations. The individual components are installed from the inside of the shoring tower. The required components are passed up with protection provided by the existing guardrails.

For high towers, additional platform levels can similarly be carried upwards. The platforms can remain in the tower; opened platform surfaces are arranged opposite to each other. In the process, the opened platforms are secured with cotter pins.

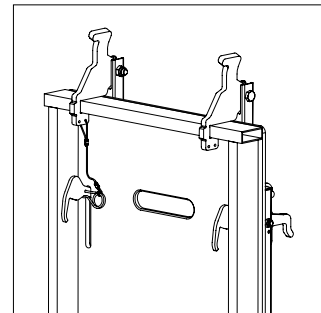

**PERI UP Flex Shoring Tower
MDS K system components
provide high, certified quality**

- AFNOR-certified traceability of the manufacture of PERI UP system components
- Strict quality control in the production process
- Load-bearing capacity calculation according to EN 12812

Accelerated working operations

with only a minimum of system components and constantly repeated assembly steps

The reduction in the number of individual components by up to 50 % compared to conventional shoring systems in the project solution makes the use of the Shoring Tower MDS K quicker and more cost-effective.

The reduction in the dead weight as well as the number of required working steps, simplifies and accelerates the utilisation of the shoring tower. Simple assembly steps and a consistent and logical workflow make the system extremely effective. The consistency of all assembly steps also ensures the correct dismantling of the tower in the reverse order without any exceptions.



Material composition for a shoring tower with height of 4.50 m.

Easier working with only a minimum of system components

The low number of system components ensures an accelerated planning process. In addition, it simplifies the logistics processes, thus ensuring that the correct components are available.

System overview

- End Frame MDS 50
- Frame MDS 100 K
- Intermediate Frame MDS 50
- Base Frame MDS
- Platform MDS 125
- Core components from PERI UP Flex: Head and Base Spindles including Spindle Locking, Ledger UH Plus, Ledger Brace UBL

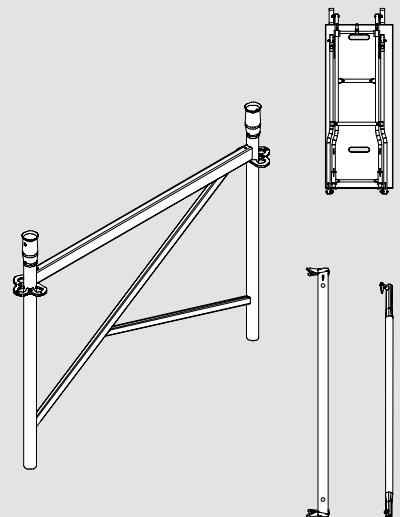



The main feature of the PERI UP Flex system is the particularly rigid node connection between the rosettes of the standards and the ledgers.

When assembling the towers, the frames are very easily connected to the rosettes by means of ledgers. The wedge connection guarantees very fast assembly. By inserting the wedge head into the rosette, the wedge drops by force of gravity into the hole and then locks in position.



System diagonals are installed for bracing purposes; no tools are required.



The joint area with tulip-shaped sleeves allows quick insertion of the frames and accurately-fitting connections. A 10-m-high shoring tower can easily be moved with the crane.

Effortless handling

due to the low weight and ergonomically advantageous working operations in the centre of the body



Low individual weights of the system components to be moved and optimised working movements create the prerequisites for an ergonomic body posture. Virtually all working steps required for handling the Shoring Tower MDS K have been optimised down to the last detail in this respect.

Assembly and dismantling of the tower is carried out with the fitter to a large extent in an upright position. All elements are compact and light – no system component weighs more than 16 kg.

The Platform MDS weighs 14.8 kg and is, however, always attached on one side in the frame during assembly. The actual weight that is to be moved is therefore reduced to only 7.4 kg.

In addition, the compact shoring frame is always moved at the height of the body.



After attaching the frame to the tulip under 45°, the frame is turned into a vertical position.



The frame slides into the end position under its own weight.



The intermediate guardrail of the Platform MDS can also be used as a climbing aid. The distance is 50 cm on the "red" side and 33 cm on the "yellow" side.



The ledgers can be quickly mounted from a safe position. The self-securing ledger assembly with the Gravity Lock increases the level of working safety.



With the ledger assembly, the wedge falls into the opening of the rosette through its own force of gravity and locks automatically. The rosette node connection is extremely rigid with a high loading capacity.



Direct and safe access to the Head Spindles and other additional work is always guaranteed through the Platform MDS.

PERI UP Flex Shoring Tower MDS K at a glance

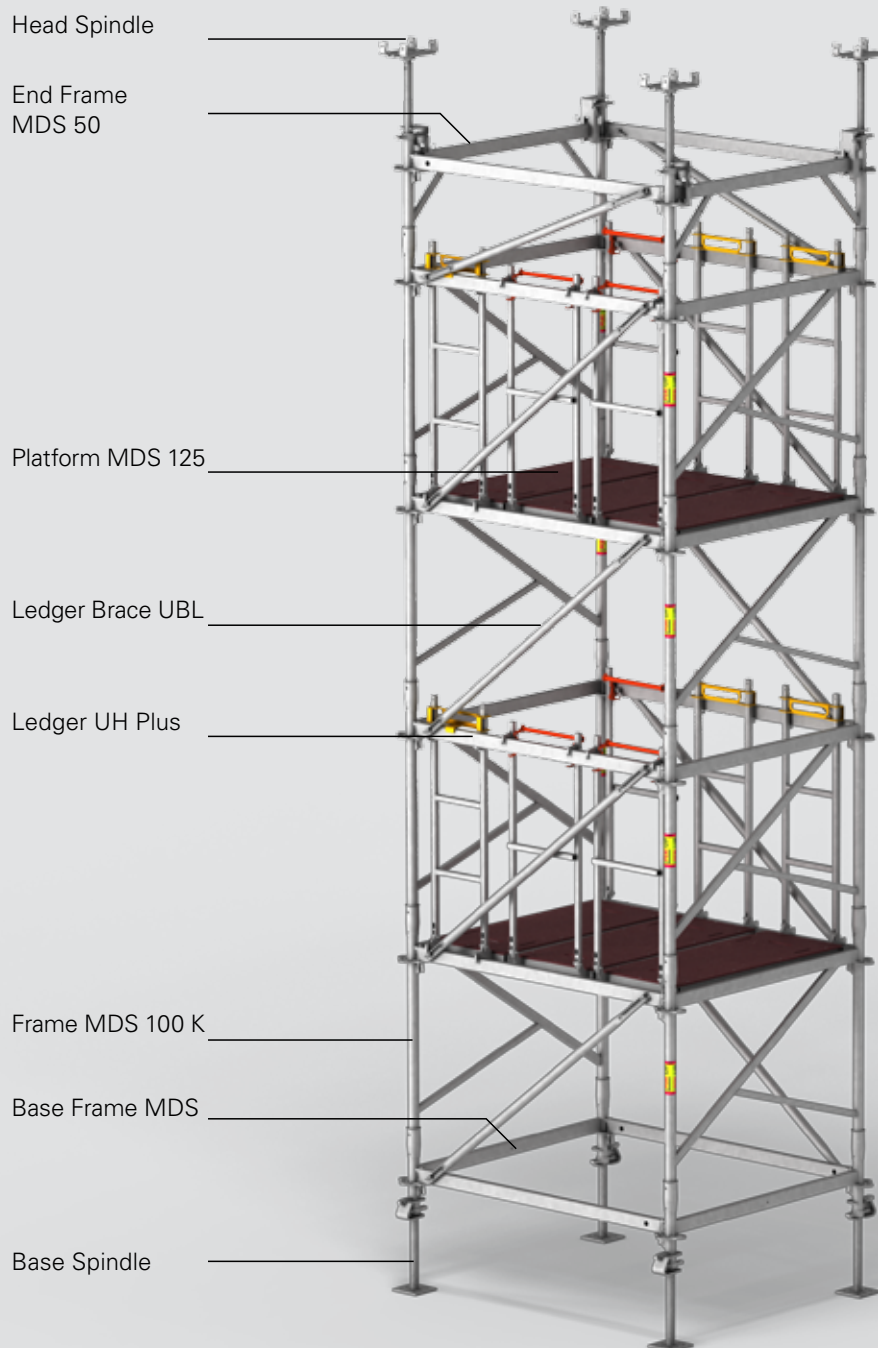

The rosettes used to connect the PERI UP Flex system components and the Gravity Lock are advantageous features of the PERI UP Flex modular scaffolding. These also characterise the PERI UP Flex Shoring Tower MDS K.



With the Gravity Lock, the ledgers can be assembled quickly in the ground plan and at great heights. Tubes and couplers are not required.



The compatibility with the PERI UP Rosett Flex modular scaffolding extends the application possibilities.

Height adjustment and loading multiplication

Height adjustment

By combining the Frame MDS 100 K with the Intermediate Frames MDS 50, the height of the Shoring Tower MDS K can be adjusted in 50-cm-increments. The last level is always formed by the End Frame MDS 50.

Fine adjustments for adapting to the final height are carried out continuously by means of the Head and Base Spindles.

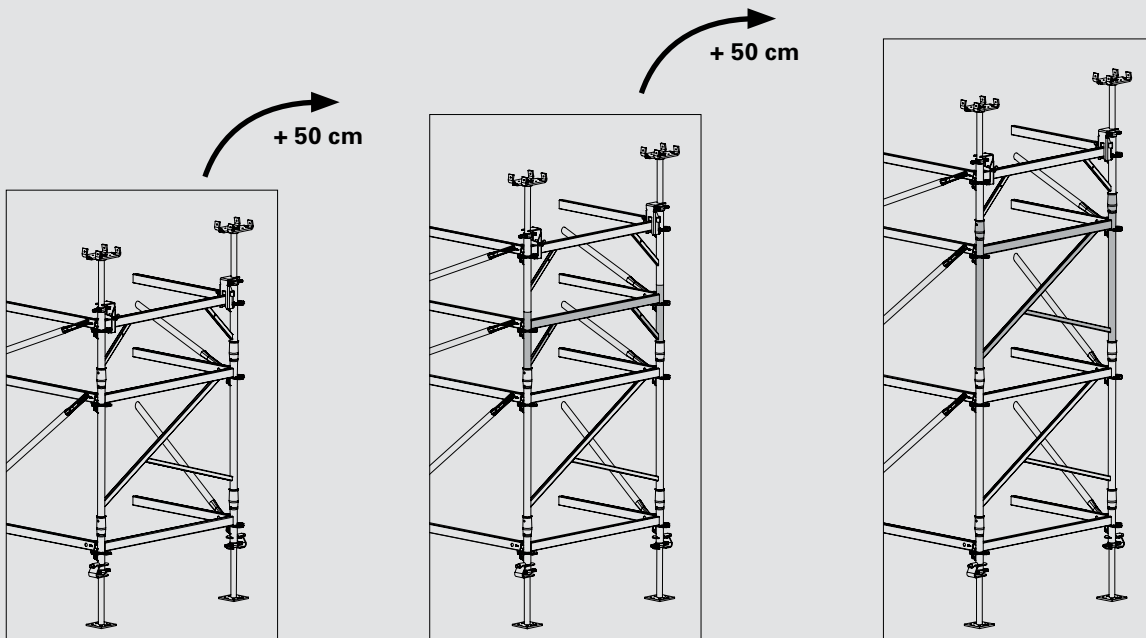

The next height level is formed by using the Intermediate Frame MDS 50 or Frame MDS 100 K. The End Frame MDS forms the top closure in each case.

Shoring tower with additional frame

With PERI UP Ledgers, the number of legs and thus – according to the “additional frame principle” – the load-bearing capacity can be multiplied while simultaneously minimising material usage.

To transfer concentrated loads, up to 2 additional frames can be connected to an individual tower. The spacing between the frames is freely selectable according to the static requirements; max. bay length in the direction of the ledger ≤ 1.50 m. Recommended spacings are 25 cm and 150 cm.

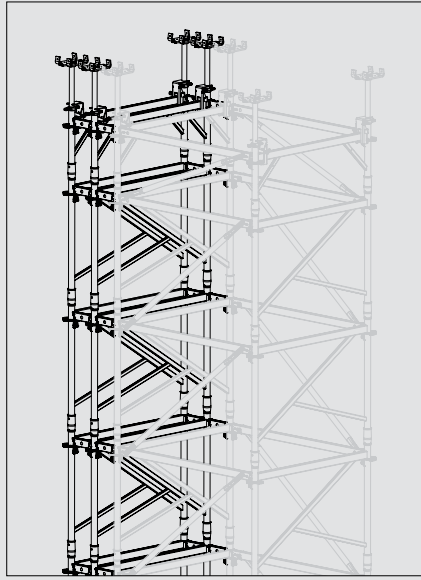

By using PERI UP Flex system components, the tower layout can be flexibly adapted in the longitudinal direction. Due to the modular structure, the tower cross-section is perfectly matched to the load requirements – while still maintaining a high level of safety.

Possible tower dimensions are:
125 cm x 100 cm / 150 cm / 200 cm /
250 cm / 300 cm

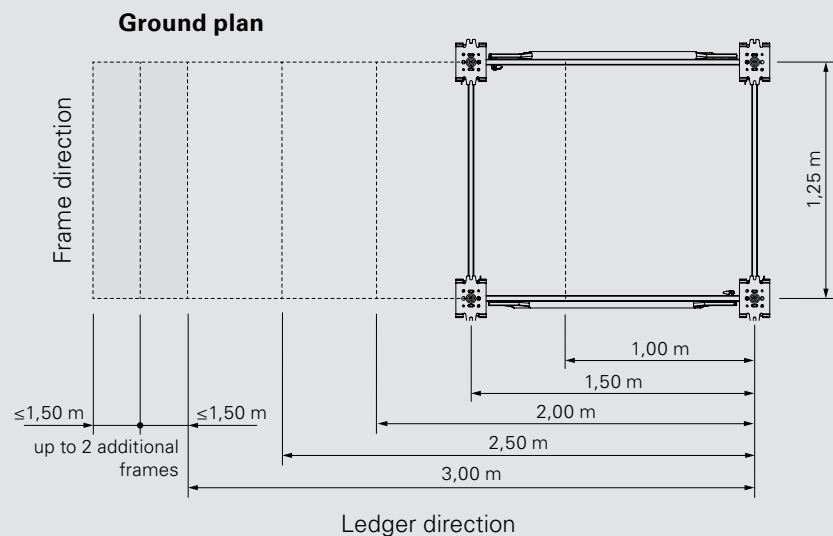

Moving with the crane or Trolley with Winch

4-sling lifting gear is to be attached to move shoring towers by crane with or without additional frames.

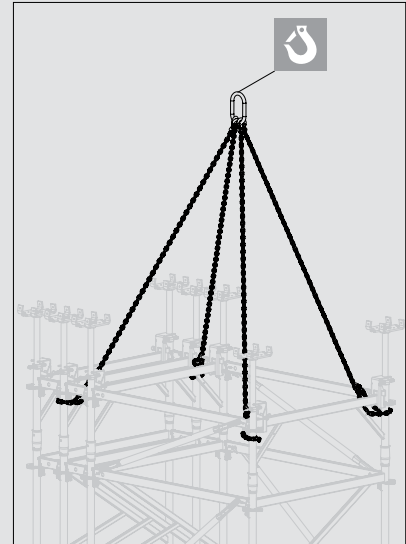
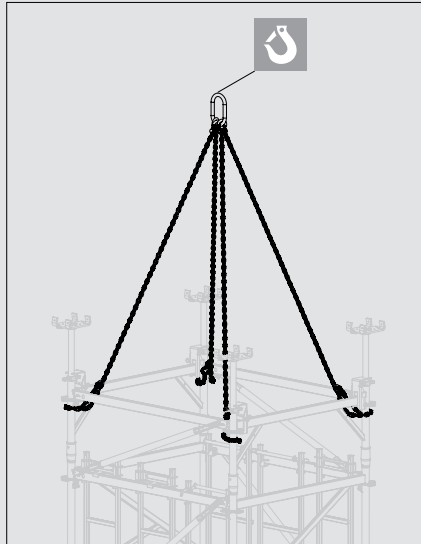

Head and Base Spindle Locking must be fitted if the shoring tower is moved by crane. Both allow subsequent adjustment of the spindle extension length without having to remove the Spindle Locking.



The shoring towers without additional frames can be moved quickly using 2x Trolley with Winch. The permissible load-bearing capacity of the equipment is 1.0 t.

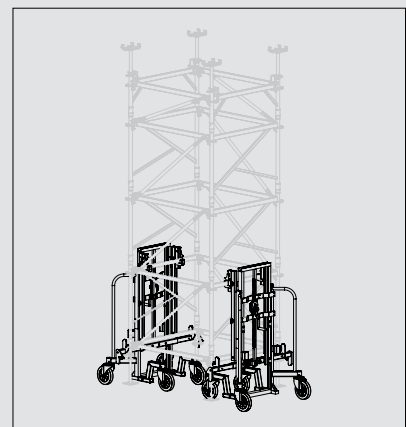

Storage and transportation

PERI storage and transport systems are suitable for lifting by crane or forklift. All pallets and stacking devices can be lifted using both the longitudinal and front sides.

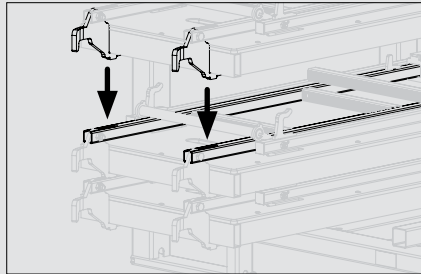

Platform MDS 125

A maximum of 15 Platform MDS 125 (3 platforms side by side, 5 layers one on top of another) can be stacked in the Pallet RP 150; the cams engage the stacking pockets.

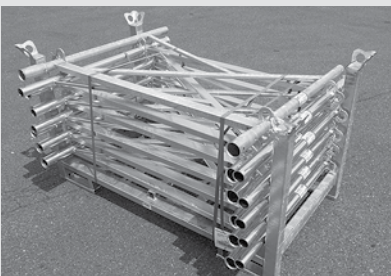

Frame MDS 100 K

A maximum of 11 Frames MDS 100 K can be safely stored and transported in the PERI Ring Pallet RP 120.



Intermediate Frame MDS 50

The Pallet RP 120 holds a maximum of 28 Intermediate Frames MDS 50 (14 packages each consisting of 2 Intermediate Frames alternately protruding on one side).



End Frame MDS 50

The Pallet RP 120 is also used for the End Frames, providing space for max. 20 End Frames (10 packages with 2 End Frames fitted inside of each other, alternately protruding on one side).

PERI UP Flex Shoring Tower MDS K



Item no.	Weight kg
125631	14.800

Platform MDS 125

Technical Data

Permissible load 2.0 kN/m².

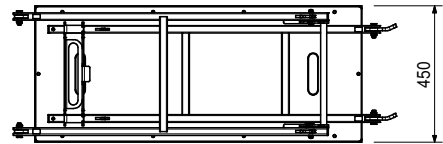
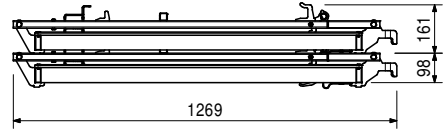
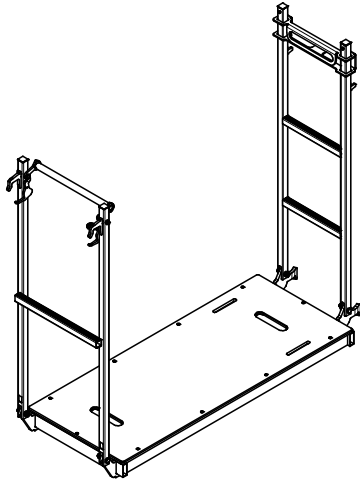

112012

6.650

Base Frame MDS

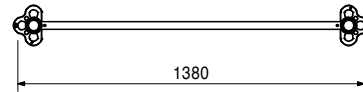
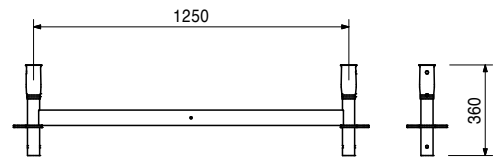
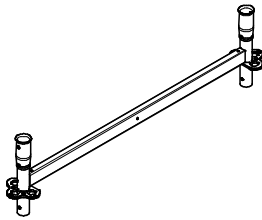

131806

15.100

Frame MDS 100 K

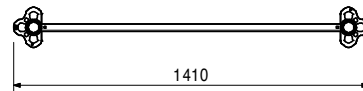
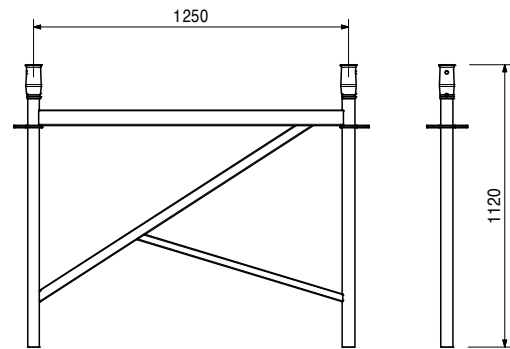
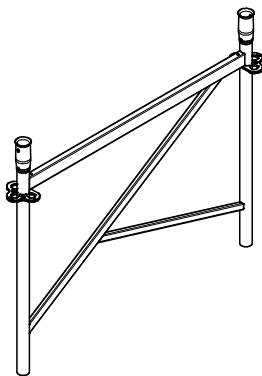

PERI UP Flex Shoring Tower MDS K



Item no.	Weight kg
112059	8.640

End Frame MDS 50

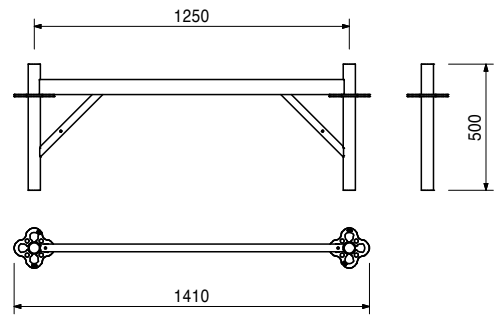
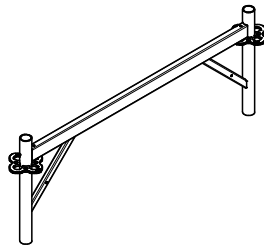

112034	9.190
--------	-------

Intermediate Frame MDS 50

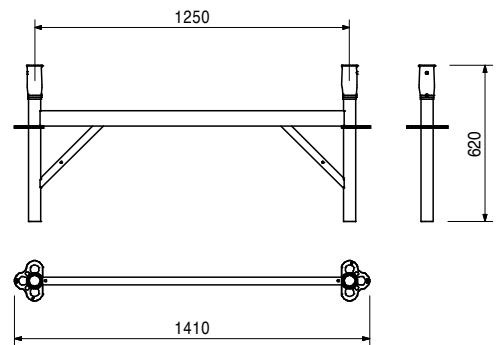
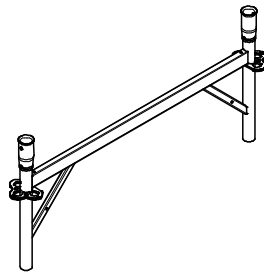

019780	5.250
--------	-------

Base Spindle TR 38-70/50

For heavily loaded shoring.

Note

With captive silver Quick Jack Nut.

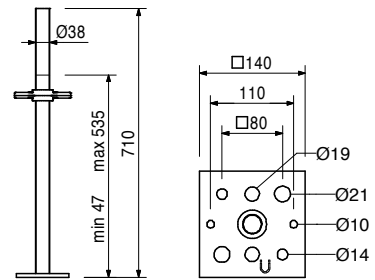
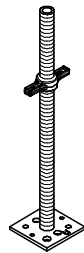

100411	3.390
--------	-------

Adj. Base Plate UJB 38-50/30

Note

With captive red Quick Jack Nut.

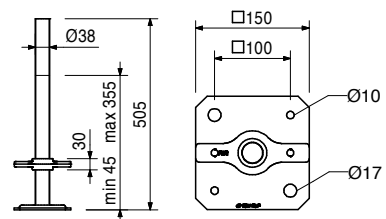

Item no.	Weight kg
019950	7.770

Cross Forkhead TR 38-70/50

Tilt-resistant head spindle for holding one or two GT 24 or VT 20 Girders.

Note

With captive Quick Jack Nut.

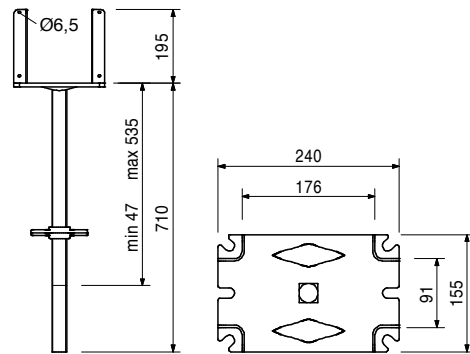
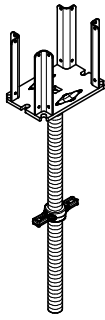

Accessories

028590	0.568
--------	-------

Tension Strap 16-25, galv.

116081	7.040
--------	-------

Head Spindle-2 TR 38-70/50

Maximum inclination of the head plate on all sides 4.4°.

Note

With locking device and captive Quick Jack Nut.

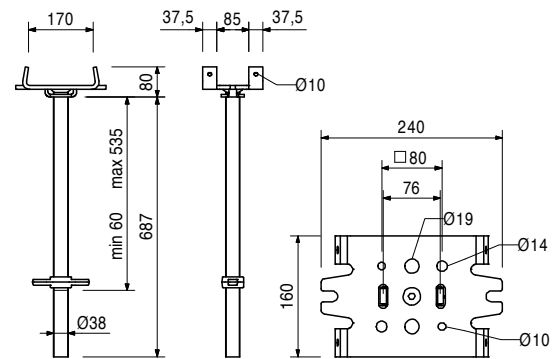
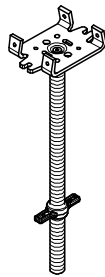

Accessories

028590	0.568
018300	0.564

Tension Strap 16-25, galv.

Cross Strap, galv.

109563	1.460
--------	-------

Head Spindle Locking UJH

Connects Head Spindle and Section Spindle with Ledger UH when moving.

Complete with

1 pc. 018060 Cotter Pin 4/1, galv.

Technical Data

Permissible load 2.1 kN.

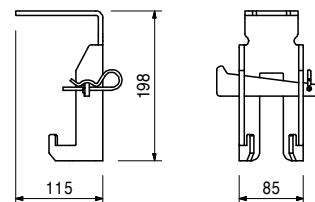
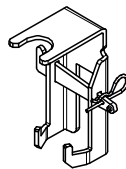

Item no.	Weight kg
100863	1.020

Spindle Locking UJS

Secures the Adjustable Base Plates and Section Spindles Ø 38 mm in the leg while moving.



Technical Data

Permissible load 1.5 kN.

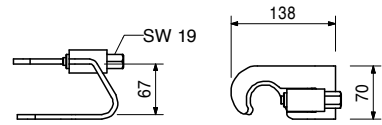

		Ledgers UH Plus
114613	1.420	Ledger UH 25 Plus
114595	2.070	Ledger UH 50 Plus
114629	2.730	Ledger UH 75 Plus
114632	4.390	Ledger UH 100 Plus
114638	5.340	Ledger UH 125 Plus
114641	4.720	Ledger UH 150 Plus
117032	5.380	Ledger UH 175 Plus
114645	6.040	Ledger UH 200 Plus
116356	6.700	Ledger UH 225 Plus
114648	7.360	Ledger UH 250 Plus
114651	8.680	Ledger UH 300 Plus
114654	11.400	Ledger UH 400 Plus

L	X
204	250
454	500
704	750
954	1000
1204	1250
1454	1500
1704	1750
1954	2000
2204	2250
2454	2500
2954	3000
3954	4000

Note

Longitudinally-stamped for easier identification.

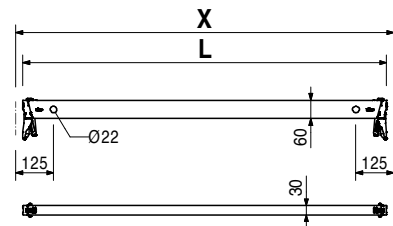
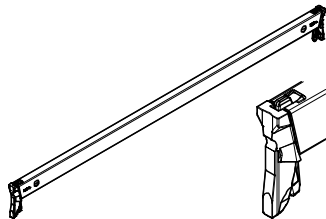

Item no.	Weight kg		L	X	Y
		Ledger Braces UBL			
115156	2.660	Ledger Brace UBL 100/50	901	1000	500
115513	4.640	Ledger Brace UBL 100/150	1677	1000	1500
106613	3.610	Ledger Brace UBL 104/100	1274	1040	1000
107867	3.790	Ledger Brace UBL 150/50	1347	1500	500
100055	4.440	Ledger Brace UBL 150/100	1601	1500	1000
102846	5.340	Ledger Brace UBL 150/150	1953	1500	1500
100057	6.380	Ledger Brace UBL 150/200	2358	1500	2000
109034	6.740	Ledger Brace UBL 175/200	2500	1750	2000
104391	5.000	Ledger Brace UBL 200/50	1820	2000	500
100059	5.510	Ledger Brace UBL 200/100	2016	2000	1000
102862	6.240	Ledger Brace UBL 200/150	2305	2000	1500
100061	7.150	Ledger Brace UBL 200/200	2658	2000	2000
130282	5.620	Ledger Brace UBL 225/50	2062	2250	500
130283	6.070	Ledger Brace UBL 225/100	2236	2250	1000
117689	7.580	Ledger Brace UBL 225/200	2829	2250	2000
100063	6.640	Ledger Brace UBL 250/100	2462	2500	1000
102861	7.260	Ledger Brace UBL 250/150	2705	2500	1500
100065	8.050	Ledger Brace UBL 250/200	3010	2500	2000
104762	7.490	Ledger Brace UBL 300/50	2795	3000	500
100067	7.830	Ledger Brace UBL 300/100	2926	3000	1000
104766	8.360	Ledger Brace UBL 300/150	3133	3000	1500
100069	9.040	Ledger Brace UBL 300/200	3400	3000	2000

Mounted in the holes of the ledger.

Note

Longitudinally-stamped for easier identification.
 UBL 150/250 identical to UBL 300/50,
 UBL 225/150 identical to UBL 175/200,
 UBL 250/50 identical to UBL 200/150.
 UBL 75/200 identical to UBL 225/50.
 UBL 100/100 identical to Diagonal Strut ST 100
 (Item no. 019940).

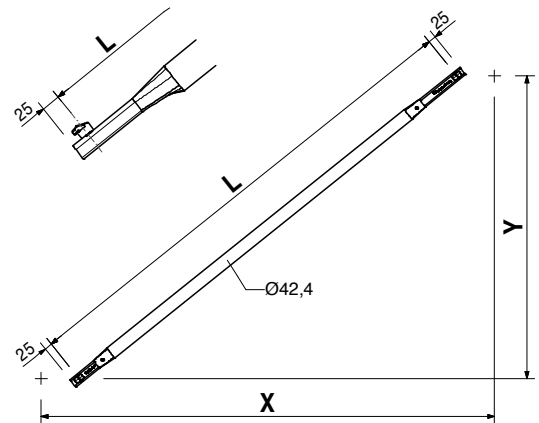
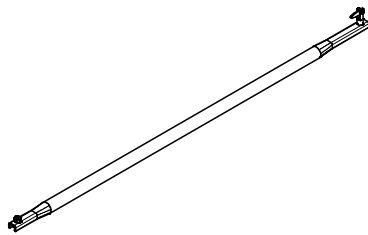

PERI UP Flex Shoring Tower MDS K



Item no.	Weight kg
019200	162.000

Trolley with Winch

For moving towers and tables with MULTIPROP, PERI UP Flex, PERI UP Flex Plus, PERI UP Flex MDS K and PD 8 with appropriate support for the system.

Note

Follow Instructions for Use!

Technical Data

Permissible load-bearing capacity 1.0 t.

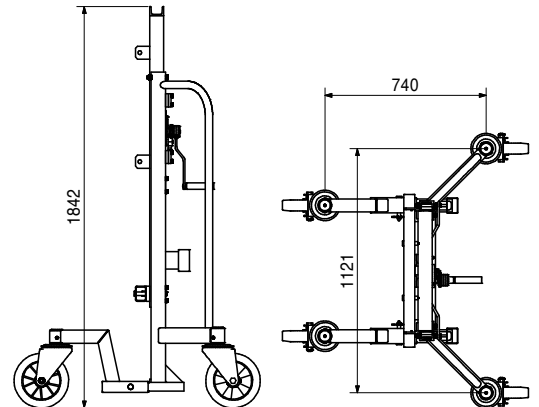
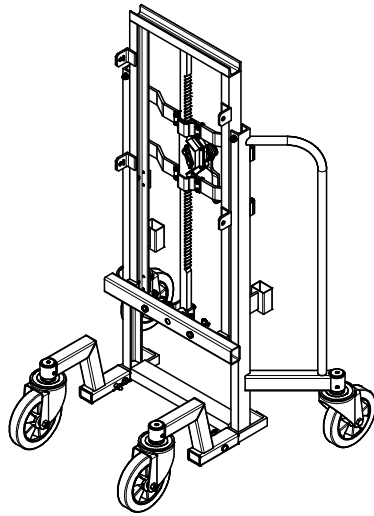

Accessories

118114	14.200
130501	27.400
118605	21.500
117954	21.200
118115	11.000

Connector MP – Trolley

Connector PERI UP – Trolley

Connector Rosett – Trolley

Connector Rosett Plus – Trolley

Connector PD 8 – Trolley

130501	27.400
--------	--------

Connector PERI UP – Trolley

For moving PERI UP Flex Shoring Tower, Shoring Tower Plus and Shoring Tower MDS K with Trolley with Winch.

Note

Consisting of 4 parts:
Support left and right.

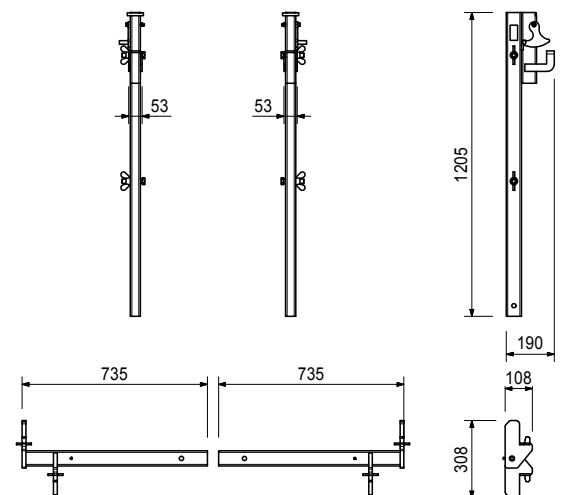
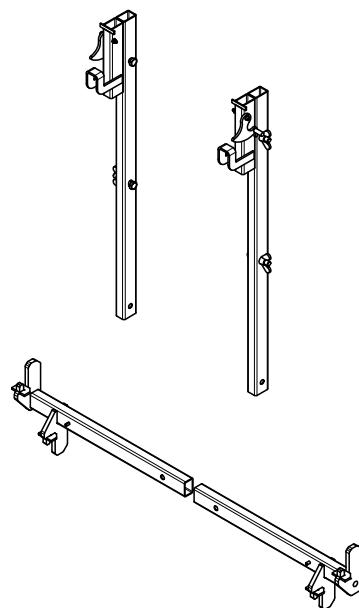

PERI International

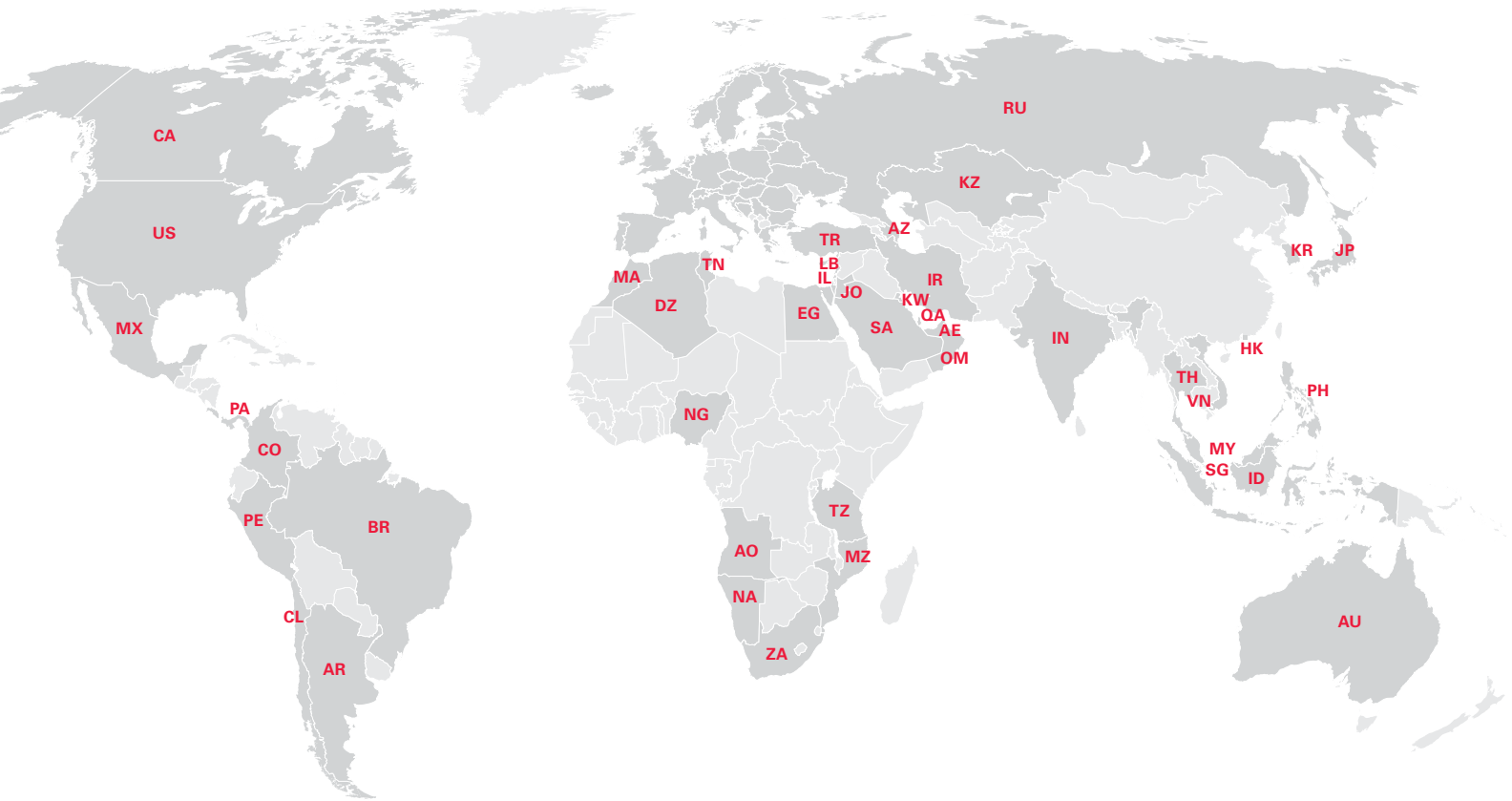

North America

- CA** Canada
PERI Formwork Systems, Inc.
www.peri.ca
- MX** Mexico
PERI Cimbras y Andamios, S.A. de C.V.
www.peri.com.mx
- PA** Panama
PERI Panama Inc.
www.peri.com.pa
- US** USA
PERI Formwork Systems, Inc.
www.peri-usa.com

South America

- AR** Argentina
PERI S.A.
www.peri.com.ar
- BR** Brazil
PERI Formas e Escoramentos Ltda.
www.peribrasil.com.br
- CL** Chile
PERI Chile Ltda.
www.peri.cl
- CO** Colombia
PERI S.A.S.
www.peri.com.co
- PE** Peru
PERI Peruana S.A.C.
www.peri.com.pe

Africa

- AO** Angola
Pericofragens, Lda.
www.peri.pt
- DZ** Algeria
S.A.R.L. PERI
www.peri.dz
- EG** Egypt
Egypt Branch Office
www.peri.com.eg
- MA** Morocco
PERI S.A.
www.peri.ma
- MZ** Mozambique
PERI (Pty.) Ltd.
www.peri.co.mz
- NA** Namibia
PERI (Pty.) Ltd.
www.peri.na
- NG** Nigeria
PERI Nigeria Ltd.
www.peri.ng
- TN** Tunisia
PERI S.A.U.
www.peri.es
- TZ** Tanzania
PERI Formwork and Scaffolding Ltd
www.peri.co.tz
- ZA** South Africa
PERI Formwork Scaffolding (Pty) Ltd
www.peri.co.za

Asia

- AE** United Arab Emirates
PERI (L.L.C.)
www.peri.ae
- AZ** Azerbaijan
PERI Representative Office
www.peri.com.tr
- HK** Hong Kong
PERI (Hong Kong) Limited
www.perihk.com
- ID** Indonesia
PT Beton Perkasa Wijaksana
www.betonperkasa.com
- IL** Israel
PERI F.E. Ltd.
www.peri.co.il
- IN** India
PERI (India) Pvt Ltd
www.peri.in
- IR** Iran
PERI Pars. Ltd.
www.peri.ir
- JO** Jordan
PERI GmbH – Jordan
www.peri.com
- JP** Japan
PERI Japan K.K.
www.peri.co.jp
- KR** Korea
PERI (Korea) Ltd.
www.perikorea.com
- KW** Kuwait
PERI Kuwait W.L.L.
www.peri.com.kw
- KZ** Kazakhstan
TOO PERI Kazakhstan
www.peri.kz
- LB** Lebanon
PERI Lebanon Sarl
lebanon@peri.de
- MY** Malaysia
PERI Formwork Malaysia Sdn. Bhd.
www.perimalaysia.com
- OM** Oman
PERI (L.L.C.)
www.peri.ae
- PH** Philippines
PERI-Asia Philippines, INC.
www.peri.com.ph
- QA** Qatar
PERI Qatar LLC
www.peri.qa
- SA** Saudi Arabia
PERI Saudi Arabia Ltd.
www.peri.com.sa
- SG** Singapore
PERI Asia Pte Ltd
www.periasia.com
- TH** Thailand
Peri (Thailand) Co., Ltd.
www.peri.co.th
- TR** Turkey
PERI Kalıp ve İskeleleri
www.peri.com.tr
- VN** Vietnam
PERI ASIA PTE LTD
www.peri.com.vn



PERI

PERI GmbH
Formwork Scaffolding Engineering
Rudolf-Diesel-Strasse 19
89264 Weissenhorn
Germany
Tel. +49 (0)7309.950-0
Fax +49 (0)7309.951-0
info@peri.com
www.peri.com

Oceania

AU Australia
PERI Australia Pty. Ltd.
www.periaus.com.au

Europe

AL Albania
PERI Kalıp ve İskeleleri
www.peri.com.tr

AT Austria
PERI Ges.mbH
www.peri.at

BA Bosnia and Herzegovina
PERI oplate i skele d.o.o
www.peri.com.hr

BE Belgium
PERI N.V.
www.peri.be

BG Bulgaria
PERI Bulgaria EOOD
www.peri.bg

BY Belorussia
IOOO PERI
www.peri.by

CH Switzerland
PERI AG
www.peri.ch

CZ Czech Republic
PERI spol. s r.o.
www.peri.cz

DE Germany
PERI GmbH
www.peri.de

DK Denmark
PERI Danmark A/S
www.peri.dk

EE Estonia
PERI AS
www.peri.ee

ES Spain
PERI S.A.U.
www.peri.es

FI Finland
PERI Suomi Ltd. Oy
www.perisuomi.fi

FR France
PERI S.A.S.
www.peri.fr

GB United Kingdom
PERI Ltd.
www.peri.ltd.uk

GR Greece
PERI Hellas Ltd.
www.perihellas.gr

HR Croatia
PERI oplate i skele d.o.o.
www.peri.com.hr

HU Hungary
PERI Kft.
www.peri.hu

IR Ireland
Siteserv Access & Formwork
www.siteservaccess.ie

IS Iceland
Armar ehf.
www.armor.is

IT Italy
PERI S.r.l.
www.peri.it

LT Lithuania
PERI UAB
www.peri.lt

LU Luxembourg
N.V. PERI S.A.
www.peri.lu

LV Latvia
PERI SIA
www.peri-latvija.lv

NL Netherlands
PERI b.v.
www.peri.nl

NO Norway
PERI Norge AS
www.peri.no

PL Poland
PERI Polska Sp. z o.o.
www.peri.com.pl

PT Portugal
Pericofragens Lda.
www.peri.pt

RO Romania
PERI România SRL
www.peri.ro

RS Serbia
PERI oplate d.o.o.
www.peri.rs

RU Russia
OOO PERI
www.peri.ru

SE Sweden
PERI Sverige AB
www.peri.se

SI Slovenia
PERI oplate i skele d.o.o
www.peri.com.hr

SK Slovakia
PERI spol. s. r.o.
www.peri.sk

UA Ukraine
TOW PERI
www.peri.ua

**The optimal System
for every Project and
every Requirement**



Wall Formwork



Column Formwork



Slab Formwork



Climbing Systems



Bridge Formwork



Tunnel Formwork



Shoring Systems



Construction Scaffold



Facade Scaffold



Industrial Scaffold



Access



Protection Scaffold



Safety Systems



**System-Independent
Accessories**



Services



PERI GmbH
Formwork Scaffolding Engineering
 Rudolf-Diesel-Strasse 19
 89264 Weissenhorn
 Germany
 Tel. +49 (0)7309.950-0
 Fax +49 (0)7309.951-0
 info@peri.com
 www.peri.com

